

# Borne Air

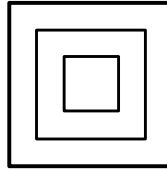
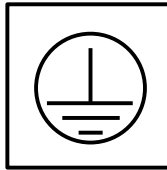
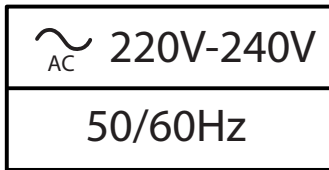

Si le câble extérieur, la source lumineuse ou le driver contenus dans ce luminaire sont endommagés, ils doivent être exclusivement remplacés par le fabricant ou son agent de maintenance ou une personne de qualification équivalente, cela afin d'éviter tout risque

If the external cable, lighting source or driver contained in this light are damaged, they have to be replaced by the manufacturer or its maintenance agent or an equally qualified worker, in order to avoid any risk

## Dimensions

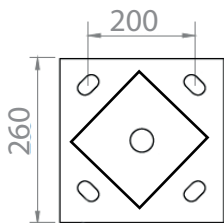

4 Tiges M14/Ø16x300 (En option)  
4 anchor bolts M14/Ø16x300 (Optional)

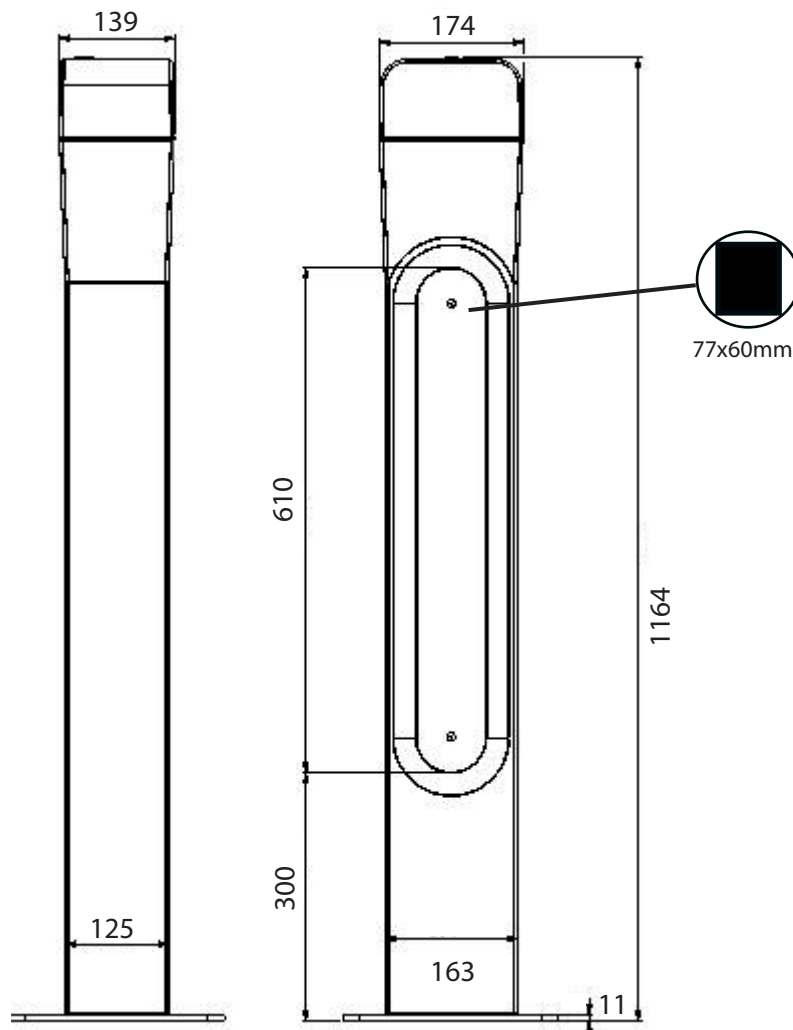

# Installation

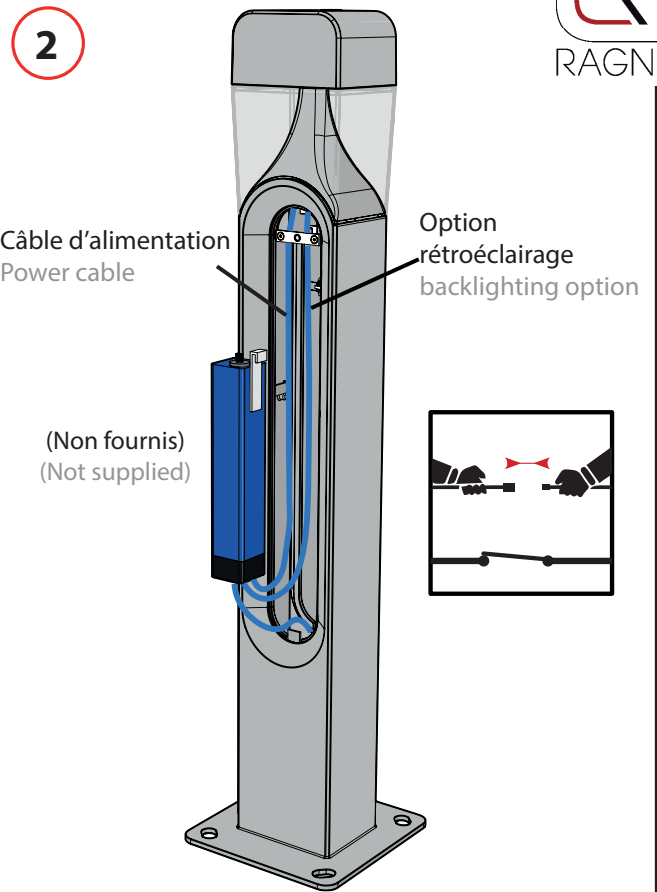
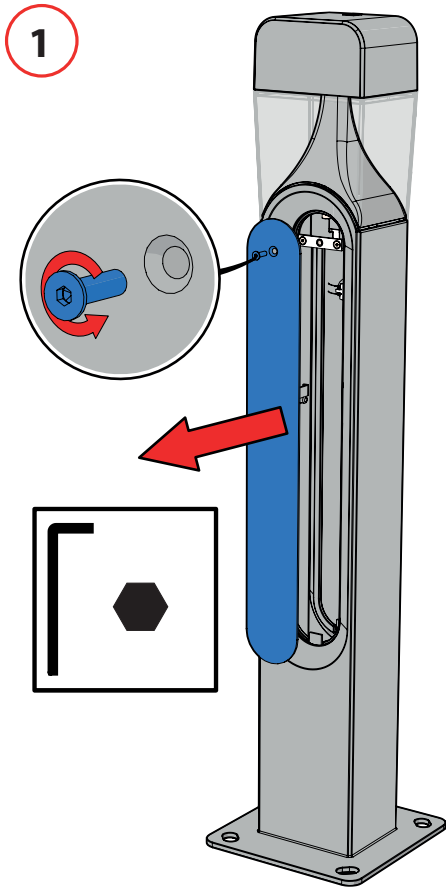

- 3 Fermer le luminaire en faisant toutes les opérations précédentes dans le sens inverse.  
Put the system back by making all the previous operations in the reverse order.

# Maintenance

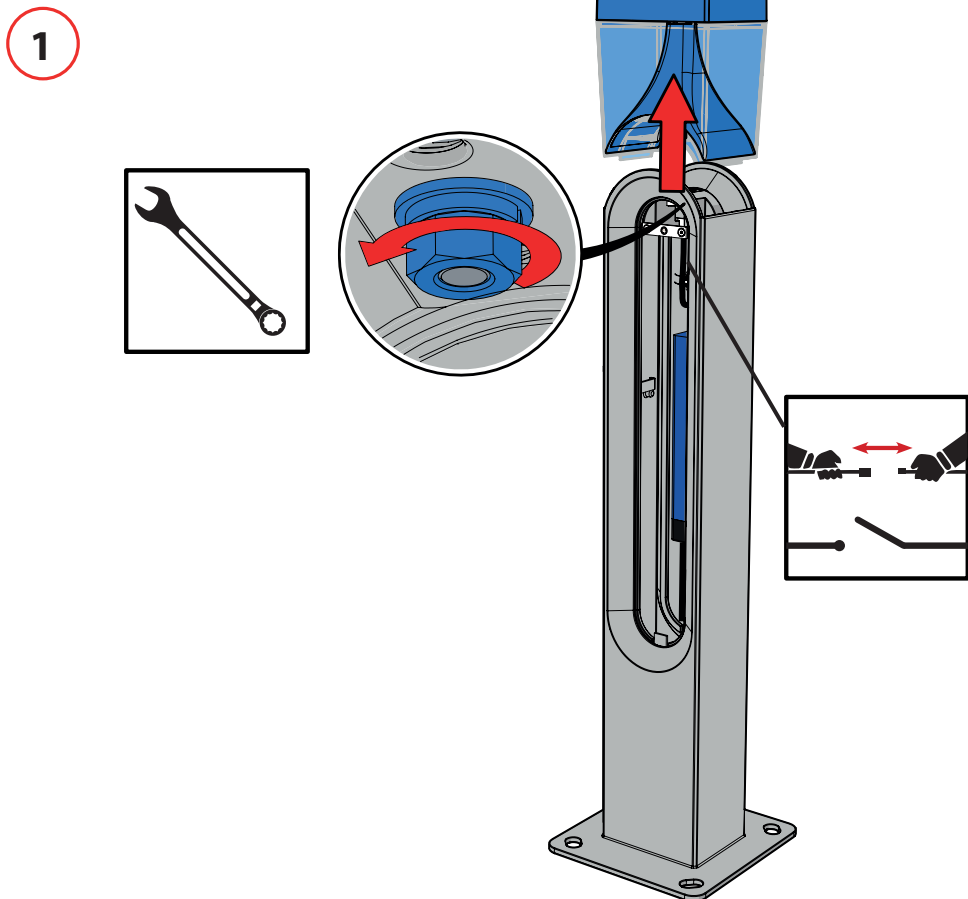

2

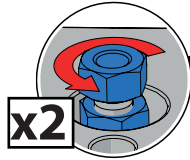

Couple de serrage  
Tightening torque  
4 N.m

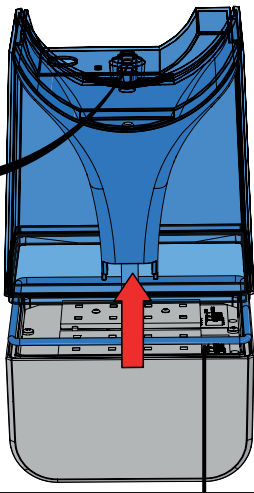

Positionnement du joint  
Positioning of the seal

3

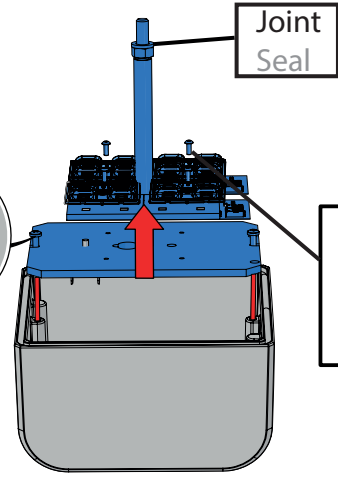
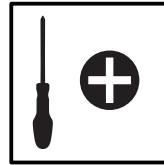
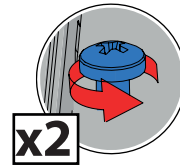

4

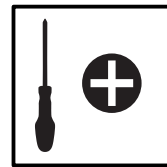
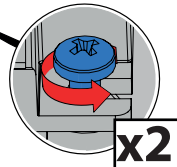
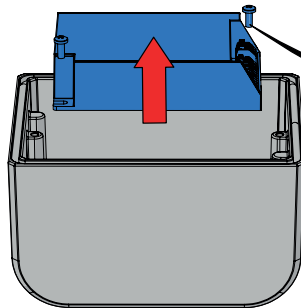

5

Fermer le luminaire en faisant toutes les opérations précédentes dans le sens inverse.  
Put the system back by making all the previous operations in the reverse order.

6

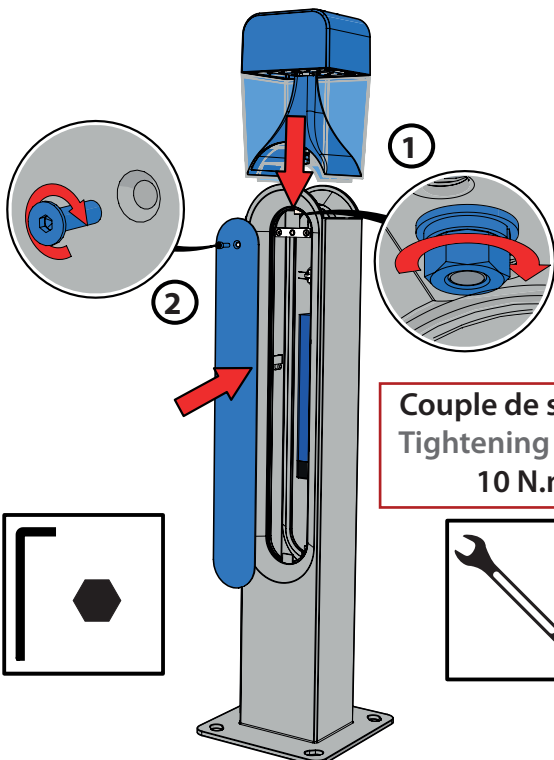

Couple de serrage  
Tightening torque  
10 N.m



## Nettoyage/ Cleaning

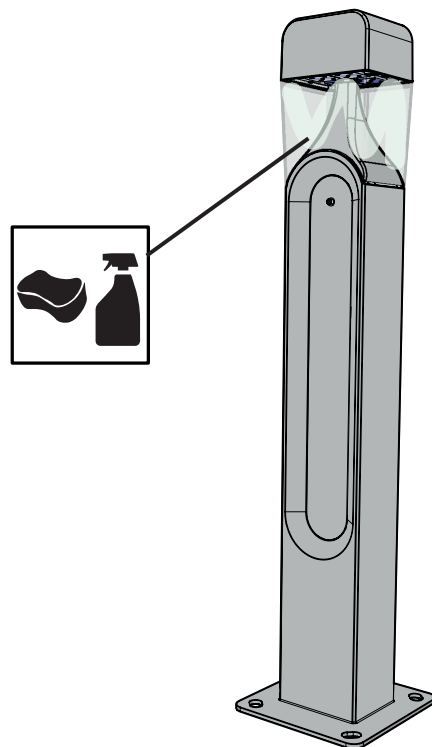

# Connexion pour les luminaires précablés

## Connection for luminaires with outgoing cable

Les connexions électriques du bloc de jonction doivent respecter la même classe d'isolation que le luminaire.

Electrical connections of the junction box have to main the same insulation class the luminaire.

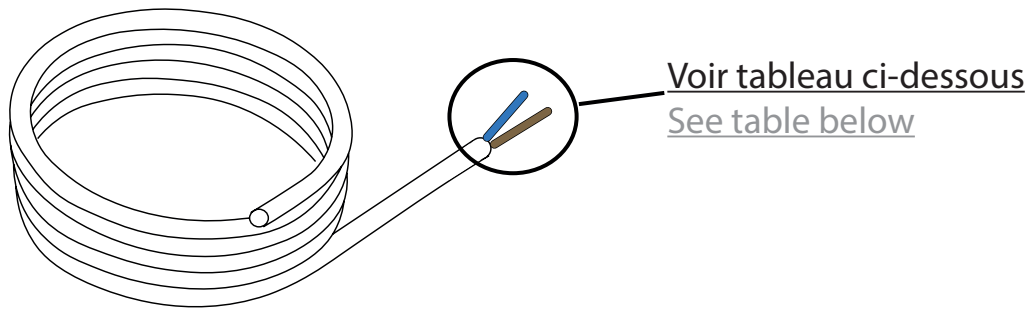

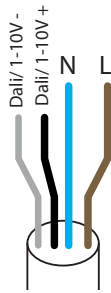
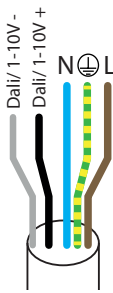
Tension assignée Nominal voltage	<b>220-240V</b> <b>Uniquement pour luminaires avec drivers</b> Only for luminaires with drivers	
Nombre de bornes et capacité de connexion assigné Number of poles and terminal section	<b><u>CLII-DALI</u></b>  <b>4x 1.5mm<sup>2</sup></b>  	<b><u>CLI-DALI</u></b>  <b>5G 1.5mm<sup>2</sup></b>  
Méthode de fixation Fixation method	<b>Dépend du bloc de jonction</b> Depend on the junction box	