

# Karo

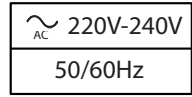

<b>FR</b>	Si le câble extérieur, la source lumineuse ou le driver contenus dans ce luminaire sont endommagés, ils doivent être exclusivement remplacés par le fabricant ou son agent de maintenance ou une personne de qualification équivalente, cela afin d'éviter tout risque.
<b>GB</b>	If the external cable, lighting source or driver contained in this light are damaged, they have to be replaced by the manufacturer or its maintenance agent or an equally qualified worker, in order to avoid any risk.
<b>ES</b>	Si el cable externo, la fuente luminosa o el driver contenidos en esta farola están dañados, deben ser sustituidos exclusivamente por el fabricante, su técnico de mantenimiento o una persona de cualificación equivalente, para evitar cualquier riesgo.
<b>DE</b>	Wenn das externe Kabel, das Leuchtmittel oder das Vorschaltgerät dieser Leuchte beschädigt sind, darf dies ausschließlich durch den Hersteller, seinem Wartungsbeauftragten oder einer gleichwertig qualifizierten Fachkraft ersetzt werden, um jedes Risiko zu vermeiden.

	Karo 900	Karo LINE 900	Karo 1200	Karo LINE 1200
Masse/Weight /Peso/Gewicht (kg)	7	9	9	10

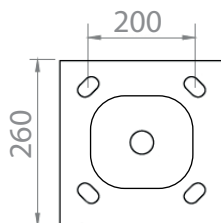

4 Tiges M14/Ø16x300 (en option)  
 4 anchor bolts M14/Ø16x300 (Optional)  
 4 varillas (Opción)  
 4 Ankerbolzen (Option)

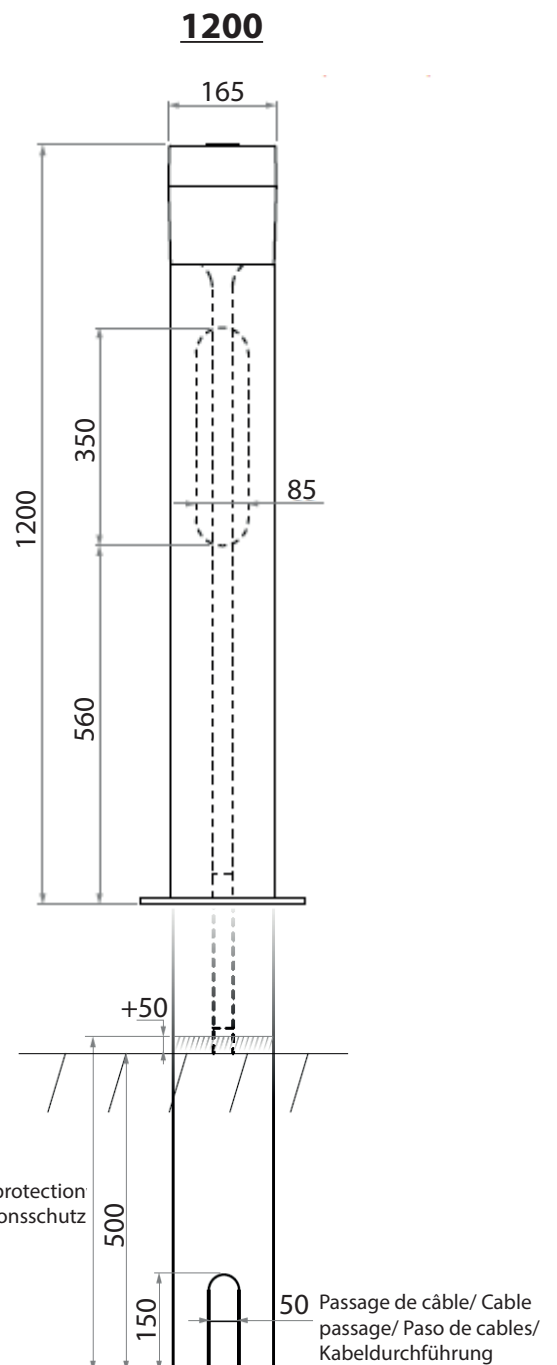
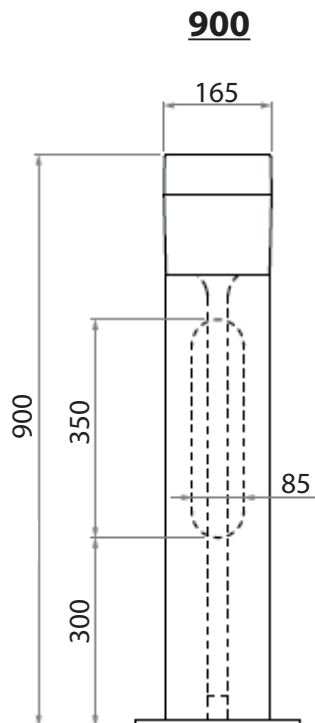

Bitumage/ Corrosion protection  
 / Asfaltar/ Korrosionsschutz

50 Passage de câble/ Cable passage/ Paso de cables/ Kabeldurchführung

FIM0227C\_Karo

Option/Opción

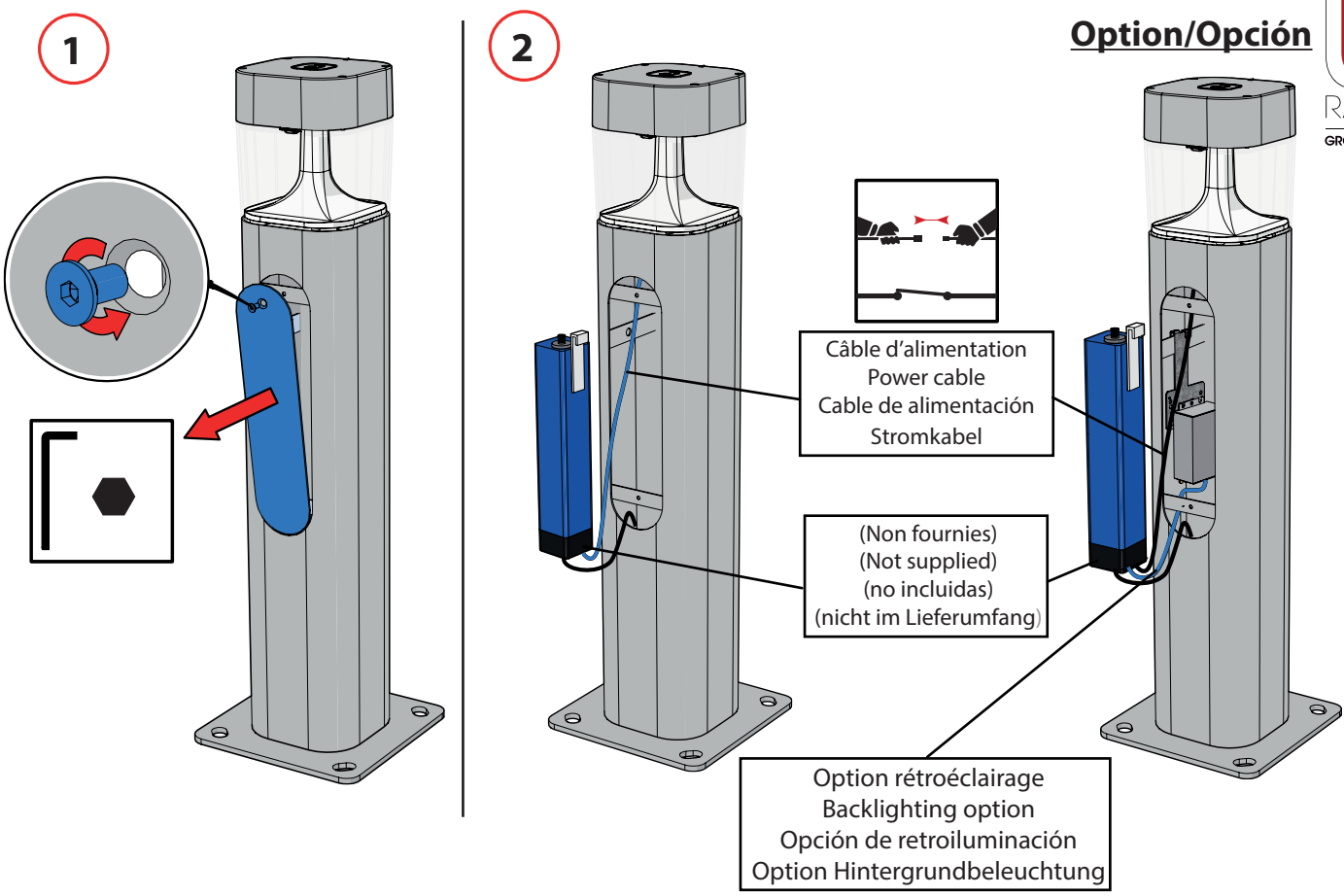

## Maintenance/ Mantedimiento/ Wartung

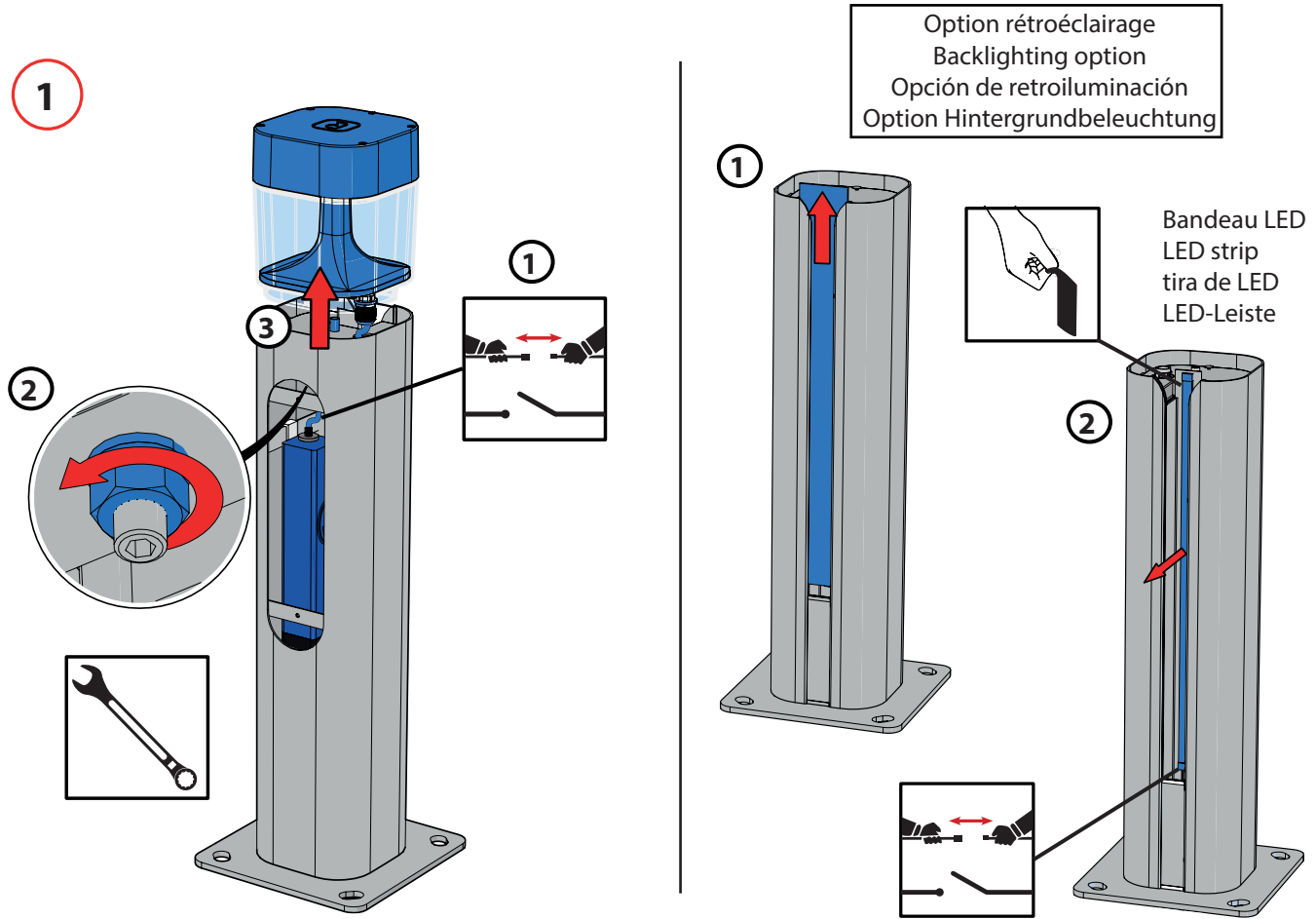

2

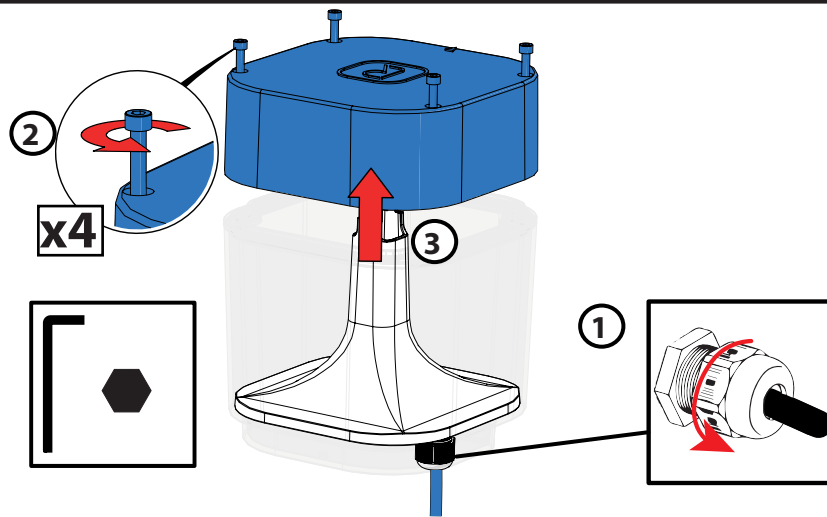

3

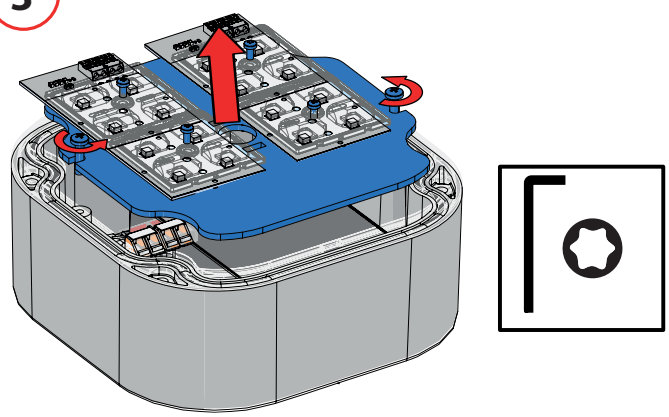

4

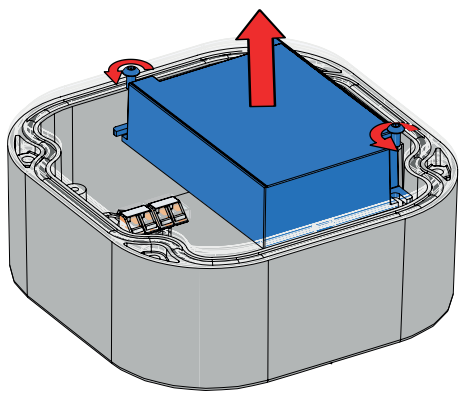
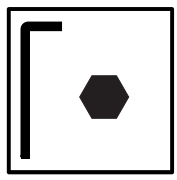

5

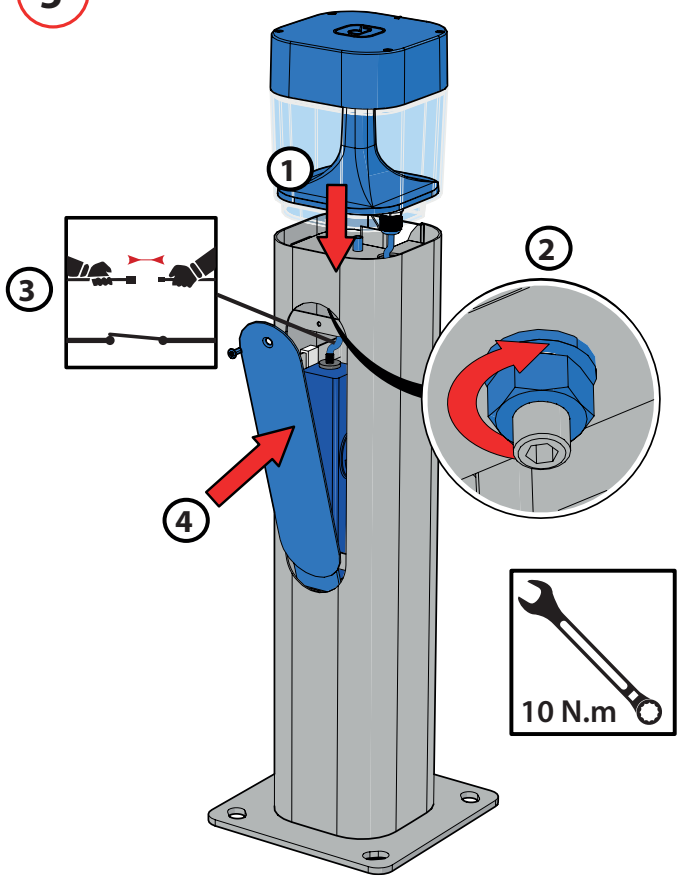

**Nettoyage/ Cleaning/**  
**Limpieza/ Reinigung**

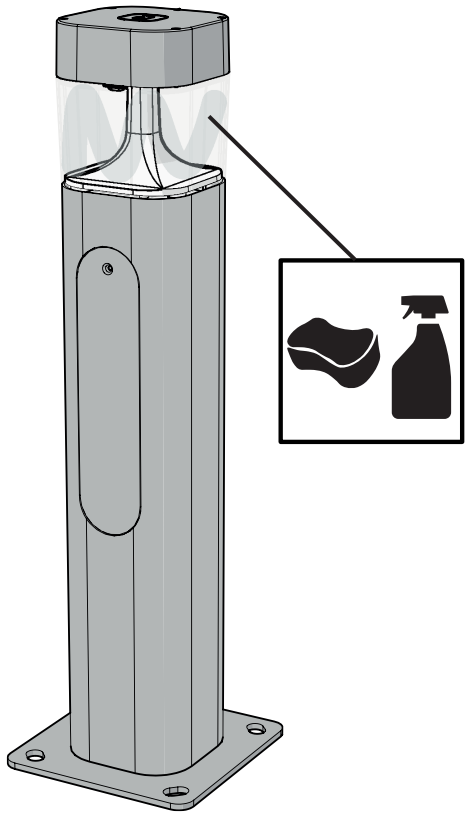

# Câblage luminaires/ Lighting wiring/ Cableado luminarias/ Verkabelung

FR	GB	ES	DE
Les connexions électriques du bloc de jonction doivent respecter la même classe d'isolation que le luminaire.	Electrical connections of the junction box have to main the same insulation class the luminaire.	Las conexiones eléctricas del bloque de terminales deben cumplir con la misma clase de aislamiento que la luminaria.	Die elektrischen Anschlüsse der Anschlussdose müssen die gleiche Isolationsklasse haben wie die Leuchte.
<b>Tension assignée</b>	<b>Nominal voltage</b>	<b>Tensión asignada</b>	<b>Nennspannung</b>
Uniquement pour luminaires avec drivers 220 - 240 V	Only for luminaires with drivers 220 - 240 V	Unicamente para luminarias con controladores 220 -240 V	Nur für Leuchten mit Vorschaltgeräten 220 - 240 V
<b>Méthode de fixation</b>	<b>Fixation method</b>	<b>Metodo de fijación</b>	<b>Befestigungsart</b>
Dépend du bloc de jonction	Depend on the junction box	Dependiendo del bloque de terminales	Abhängig von der Anschlussdose

Type de câble	Type of cable	Tipo de cable	Art des Kabels
HO7 RNF	HO7 RNF	HO7 RNF	HO7 RNF
<b>Nombre de bornes et capacité de connexion assigné</b>	<b>Number of poles and terminal section</b>	<b>Número de terminales y capacidad de conexión asignada</b>	<b>Anzahl der Pole und Anschlussbereich</b>

□ 4x 1.5mm<sup>2</sup>



⊕ 5G 1.5mm<sup>2</sup>

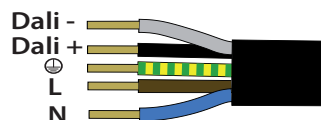

□ 5x 1.5mm<sup>2</sup>

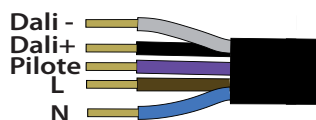

Identification des bornes	Terminal identification	Identificación de terminales	Kennzeichnung der Klemme
Driver dans luminaire	Driver in luminaire	Controlador en luminaria	Vorschaltgerät in der Leuchte

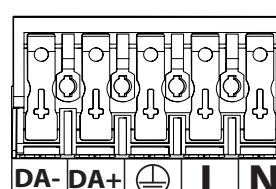
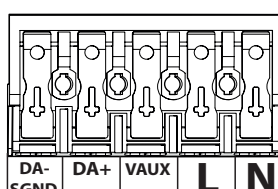
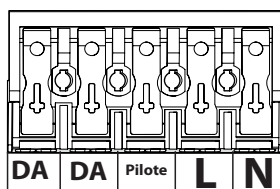

Driver en pied de poteau	Driver at the base of the pole	Controlador en la base del poste	Vorschaltgerät am Fuße des Mast
--------------------------	--------------------------------	----------------------------------	---------------------------------

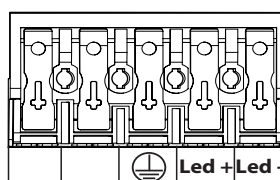
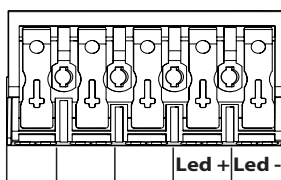

~~220-240V~~