

Lampion Glow

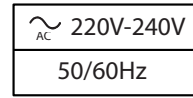

Position de fonctionnement: Verticale
Posición de funcionamiento: Vertical

Operating position: Vertical
Betriebsposition: Vertikal

Lampion Glow	
A (mm)	Ø414
B (mm)	658
C (mm)	739
Masse/Weight/Peso/Gewicht (kg)	28,9
ScX (m ²)	0.170

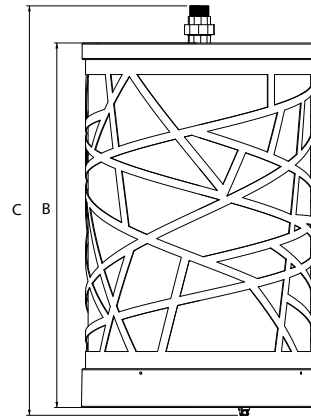
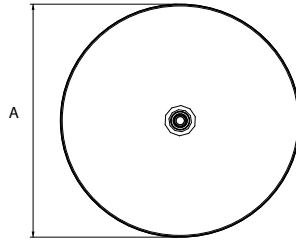

FR	Si le câble extérieur, la source lumineuse ou le driver contenus dans ce luminaire sont endommagés, ils doivent être exclusivement remplacés par le fabricant ou son agent de maintenance ou une personne de qualification équivalente, cela afin d'éviter tout risque.
GB	If the external cable, lighting source or driver contained in this light are damaged, they have to be replaced by the manufacturer or its maintenance agent or an equally qualified worker, in order to avoid any risk.
ES	Si el cable externo, la fuente luminosa o el driver contenidos en esta farola están dañados, deben ser sustituidos exclusivamente por el fabricante, su técnico de mantenimiento o una persona de cualificación equivalente, para evitar cualquier riesgo.
DE	Wenn das externe Kabel, das Leuchtmittel oder das Vorschaltgerät dieser Leuchte beschädigt sind, darf dies ausschließlich durch den Hersteller, seinem Wartungsbeauftragten oder einer gleichwertig qualifizierten Fachkraft ersetzt werden, um jedes Risiko zu vermeiden.

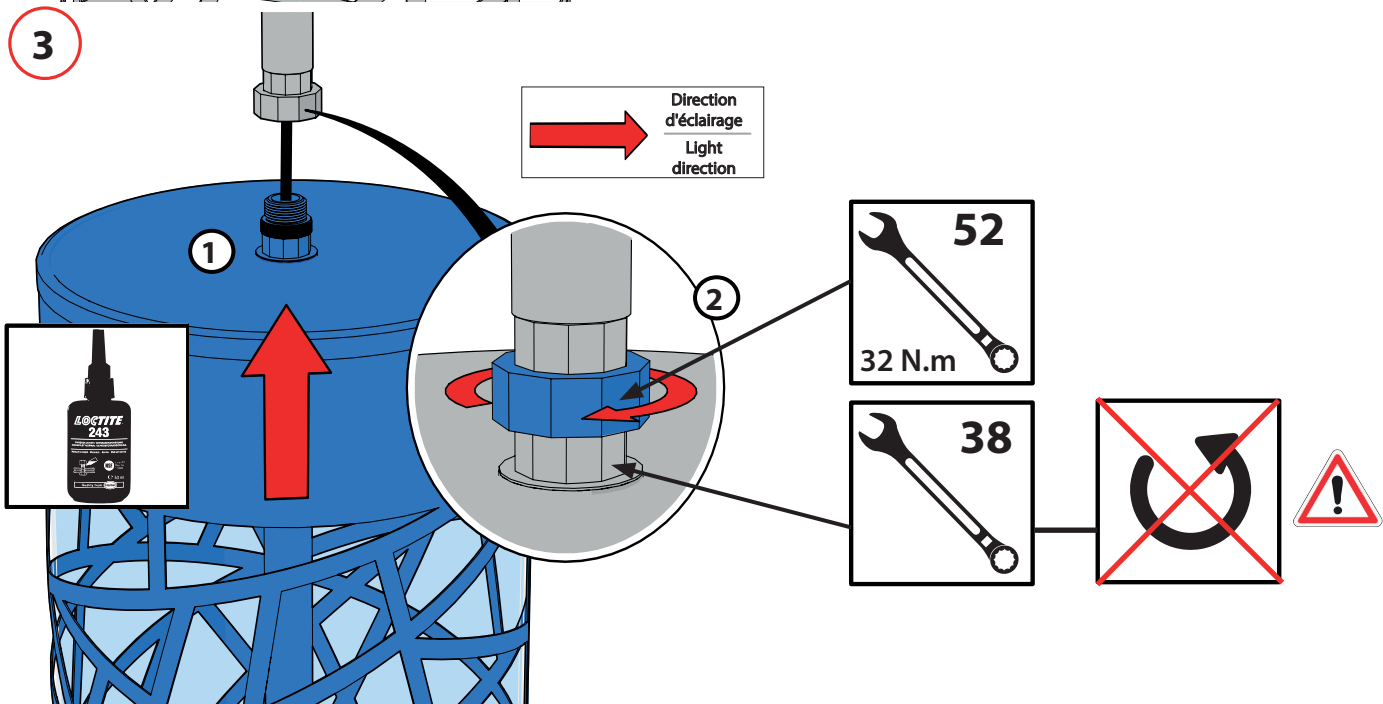
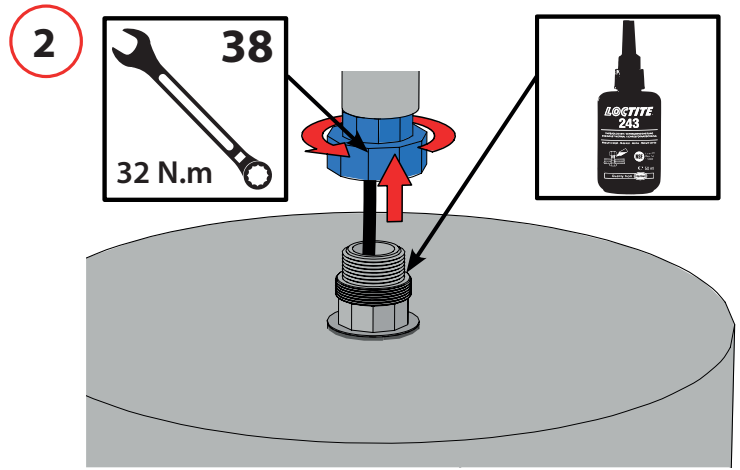
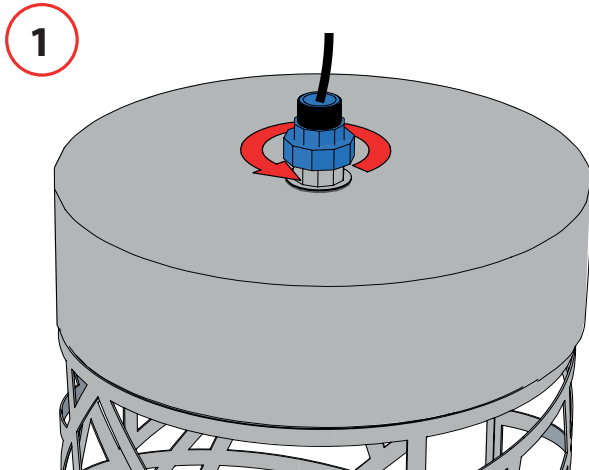

Maintenance/ Mantedimiento/ Wartung

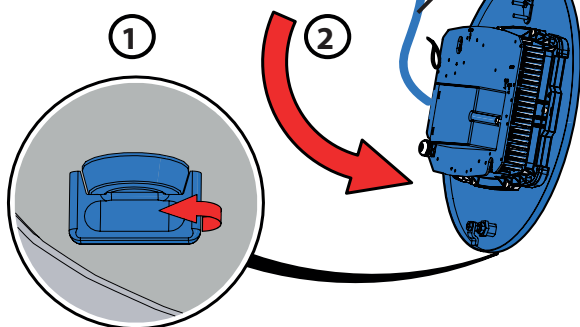
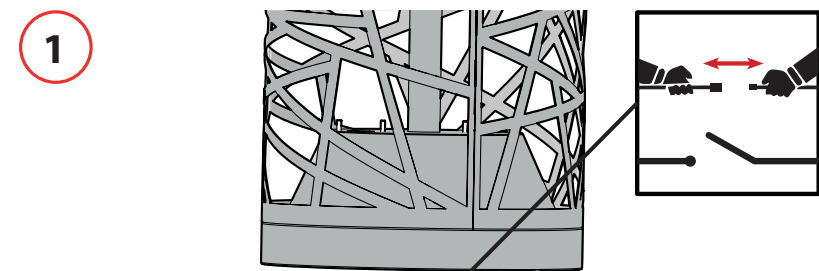

- ②
- FR Pour retirer les projecteurs
 - GB To remove the spotlights
 - ES Para quitar los focos
 - DE Zum Entfernen der Spots

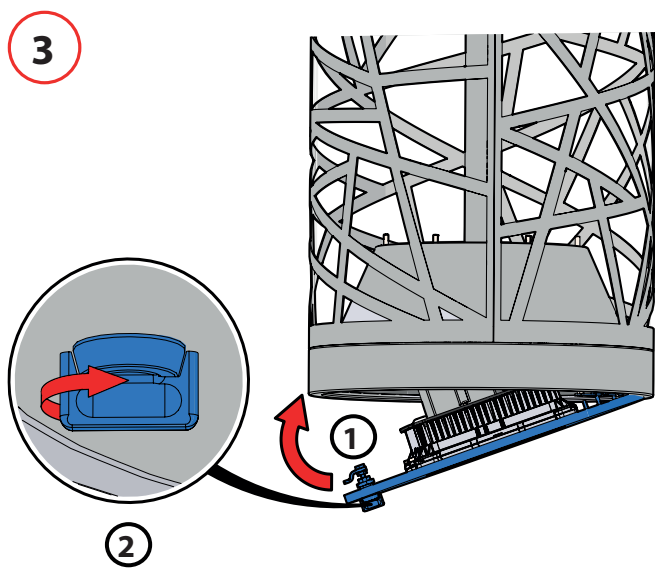
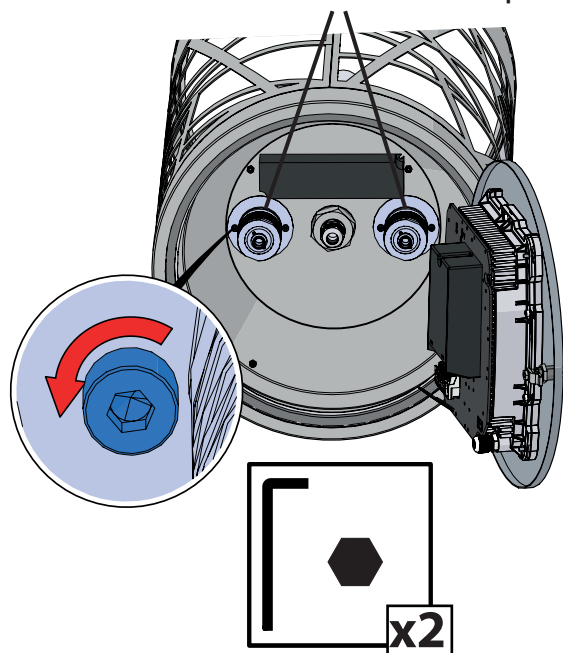

Nettoyage/ Cleaning/ Limpieza/ Reinigung

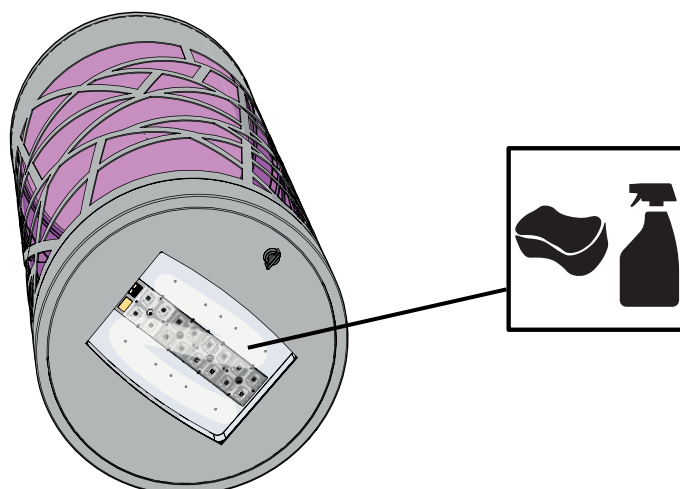

Câblage luminaires/ Lighting wiring/ Cableado luminarias/ Verkabelung

FR	GB	ES	DE
Les connexions électriques du bloc de jonction doivent respecter la même classe d'isolation que le luminaire.	Electrical connections of the junction box have to main the same insulation class the luminaire.	Las conexiones eléctricas del bloque de terminales deben cumplir con la misma clase de aislamiento que la luminaria.	Die elektrischen Anschlüsse der Anschlussdose müssen die gleiche Isolationsklasse haben wie die Leuchte.
Tension assignée	Nominal voltage	Tensión asignada	Nennspannung
Uniquement pour luminaires avec drivers 220 - 240 V	Only for luminaires with drivers 220 - 240 V	Unicamente para luminarias con controladores 220 -240 V	Nur für Leuchten mit Vorschaltgeräten 220 - 240 V
Méthode de fixation	Fixation method	Metodo de fijación	Befestigungsart
Dépend du bloc de jonction	Depend on the junction box	Dependiendo del bloque de terminales	Abhängig von der Anschlussdose

Type de câble	Type of cable	Tipo de cable	Art des Kabels
HO7 RNF	HO7 RNF	HO7 RNF	HO7 RNF
Nombre de bornes et capacité de connexion assigné	Number of poles and terminal section	Número de terminales y capacidad de conexión asignada	Anzahl der Pole und Anschlussbereich

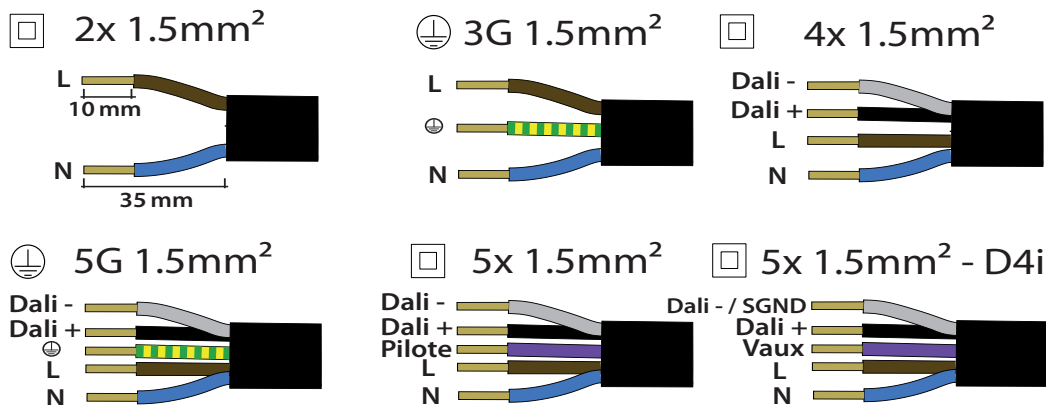

Identification des bornes	Terminal identification	Identificación de terminales	Kennzeichnung der Klemme
Driver dans luminaire	Driver in luminaire	Controlador en luminaria	Vorschaltgerät in der Leuchte

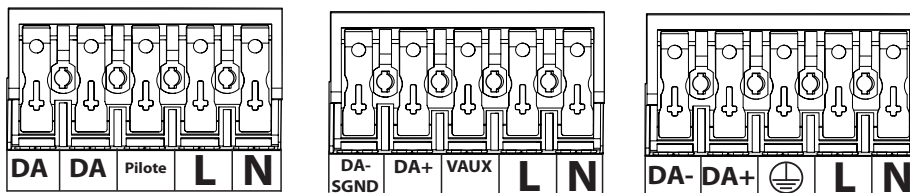

Driver en pied de poteau	Driver at the base of the pole	Controlador en la base del poste	Voschaltgerät am Fuße des Mast
--------------------------	--------------------------------	----------------------------------	--------------------------------

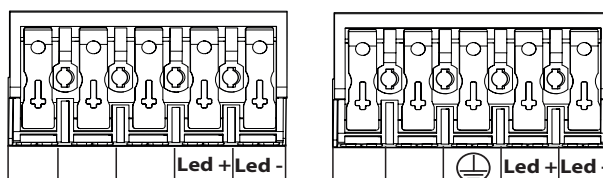

~~220-240V~~